

Crashworthy median barrier gate



GATE-GUARD®

Containment Level H2 according to DIN EN 1317-2



- ▶ The human being stands in the centre of traffic and environmental policy and in the focus of all our actions
- ▶ The road network has become an indispensable part of our living standard
- ▶ Road safety equipment has an important influence on the consequences of accidents
- ▶ The development of road safety systems helps to continuously reduce the number of road casualties
- ▶ Our road restraint systems that have proven their quality in various tests and in many years of practice make an important contribution to this
- ▶ EN ISO 9001 certification is the basis for the quality of our production



GATE-GUARD®

The pivotable restraint system at central reserve crossings.
Flexible direction of traffic at containment level H2 with integrated emergency gate.

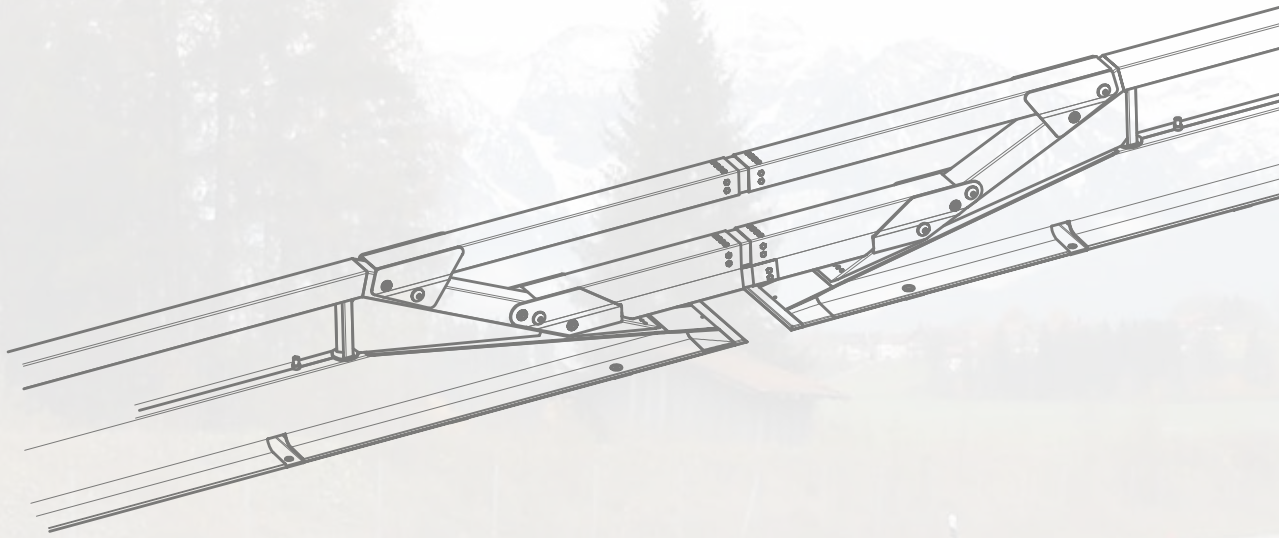

GATE-GUARD® Overview

GATE-GUARD®

The flexible restraint system

GATE-GUARD® is our own development based on the successful Vario-Guard system. It can be connected easily to all other restraint systems. Gate-Guard® is H2 tested in accordance with EN 1317-2 and CE marked. If required it can be adapted in 4m steps to the local needs.



GATE-GUARD®

Mobile system for various requirements

Rapidity is essential when emergency vehicles have to change lanes. To meet the individual demands of different road sections we offer our Gate-Guard® emergency gate in 4 and 8m length.



GATE-GUARD®

Redirection of traffic flow

An opening angle up to 60° can be achieved if medians have to be opened for construction and maintenance works.

Just two people can easily open GATE GUARD® for redirection in less than 15 minutes. No special tools are necessary. All that needs to be done is to loosen the connecting box beam elements, remove ground anchors and lower the built-in wheels with a hand crank. The system then moves very easily.

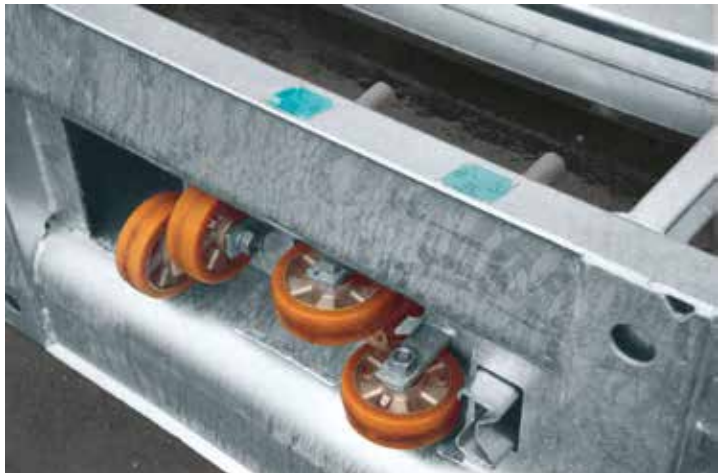

GATE-GUARD® System variations

Length	Containment level	Working width	ASI	Dynamic deflection	Test
48,80 m	H2	W7	B	1,7 m	TB11/TB51
48,00 m rapid connector					
40,80 m					
40,00 m rapid connector					



GATE-GUARD® Construction



GATE-GUARD® Real life saver

The integrated emergency gate is highlighted in colour to make it easy to find for rescue teams. It can be opened by the fire brigade or the emergency service within 2 minutes.

In case of an emergency the emergency gate is loosened at one side and pivoted at the hinge.

Where space is limited the emergency gate can be taken out completely and moved in parallel.

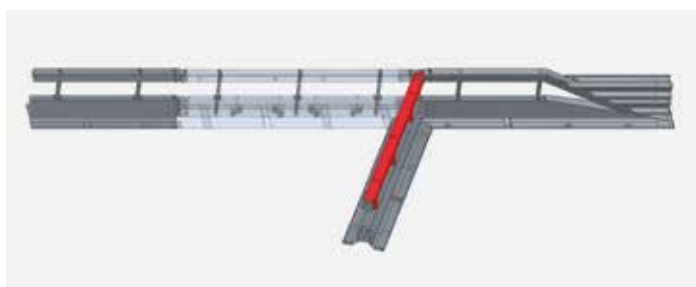



MEISER Straßenausstattung GmbH
Edmund Meiser Straße 3
D-66839 Schmelz-Limbach



+49 6887 / 9590 100



+49 6887 / 9590 188



strassenausstattung@meiser.de



strassenausstattung.meiser.de/en/

